

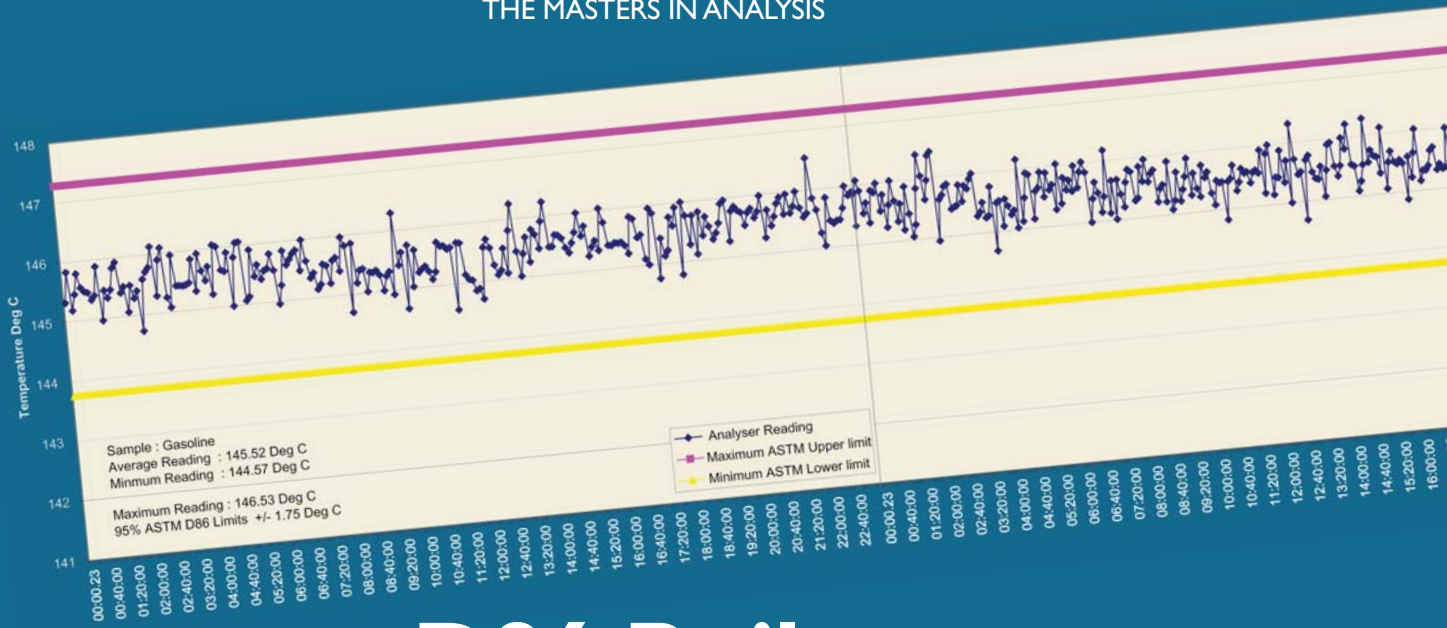

THE MASTERS IN ANALYSIS



# D86 Boiler

## CONTINUOUS SINGLE POINT BOILING POINT ANALYSER

### D86 Boiling Point Analyser

Version 2.8

1101-0159A

Date : 85/18/2086	Current stream: Diesel
Time : 11:35:42	Last switch : 11:35:41
Analysar : Geoff's	Next switch : 11:35:44
Boiling Point: 95%	Stream Temperatures
Temperature : 18.6 DegC	Kero : 17.4
Power : 21%	Naptha : 18.1
Level : 1.53%	Diesel : 18.7
Set Point : 48.88%	
Atmospheric	External Alarms
Pressure : 1883.5mBar	1 : OK
Compensation : 8.1	2 : OK
New Temp : 18.8	3 : OK
	4 : OK

Current System state : Running Normally  
 Current Error condition: Output at minimum level

Internal Alarms

External Alarms



# D86 Boiler

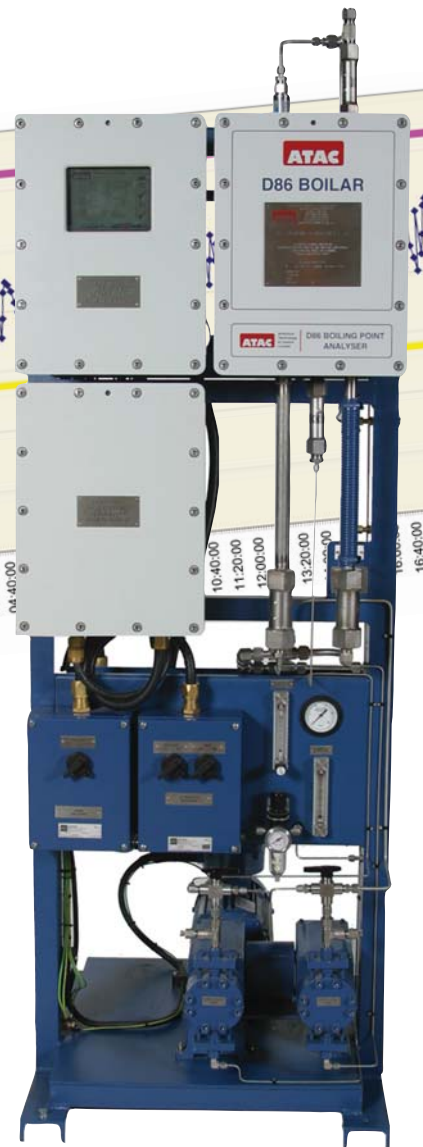
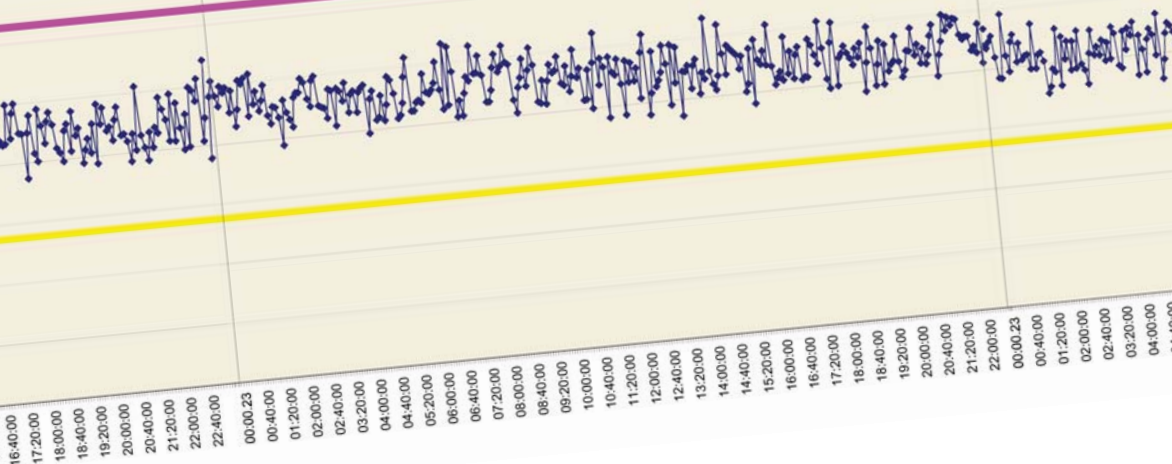

- High speed, continuous boiling point analysis
- Self diagnostics
- Correlates to ASTM D86 and ISO 3405-IP123 and surpasses test method repeatability
- Fully certified to ATEX, NEC, CSA, CTC
- Temperature 50 – 400°C for 5% – 95% distilled
- Fast response
- Accurate, reliable ultrasonic level detection
- Ideal for closed loop control of process plant

## Principle of Operation

A sample is metered into the vaporiser assembly at a constant flow. The sample then flows down a heater assembly maintained at a temperature dependant on the percentage of sample to be boiled off and the residue is collected in a measuring device. The sample is then discharged at rate proportional to the sample input rate.

The ratio of the input pump to outlet pump will define the % of sample recovered.

The temperature of the vaporiser at equilibrium is the percent recovered boiling point. This temperature is measured and transmitted.

The sample metering arrangements are infinitely variable between 5% and 95%. The percent recovered boiling point can range from 50 – 400°C.

The D86 BOILAR continuously measures the percent recovered boiling point temperatures of petroleum products from 5% – 95% in the temperature range 50 – 400°C.

Simple to operate and easy to maintain, the D86 BOILAR is the perfect choice for single point boiling point analysis.

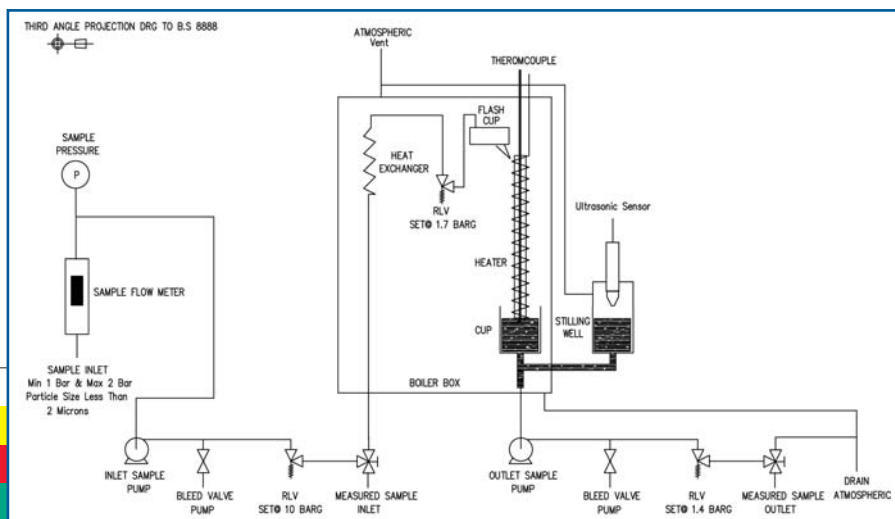

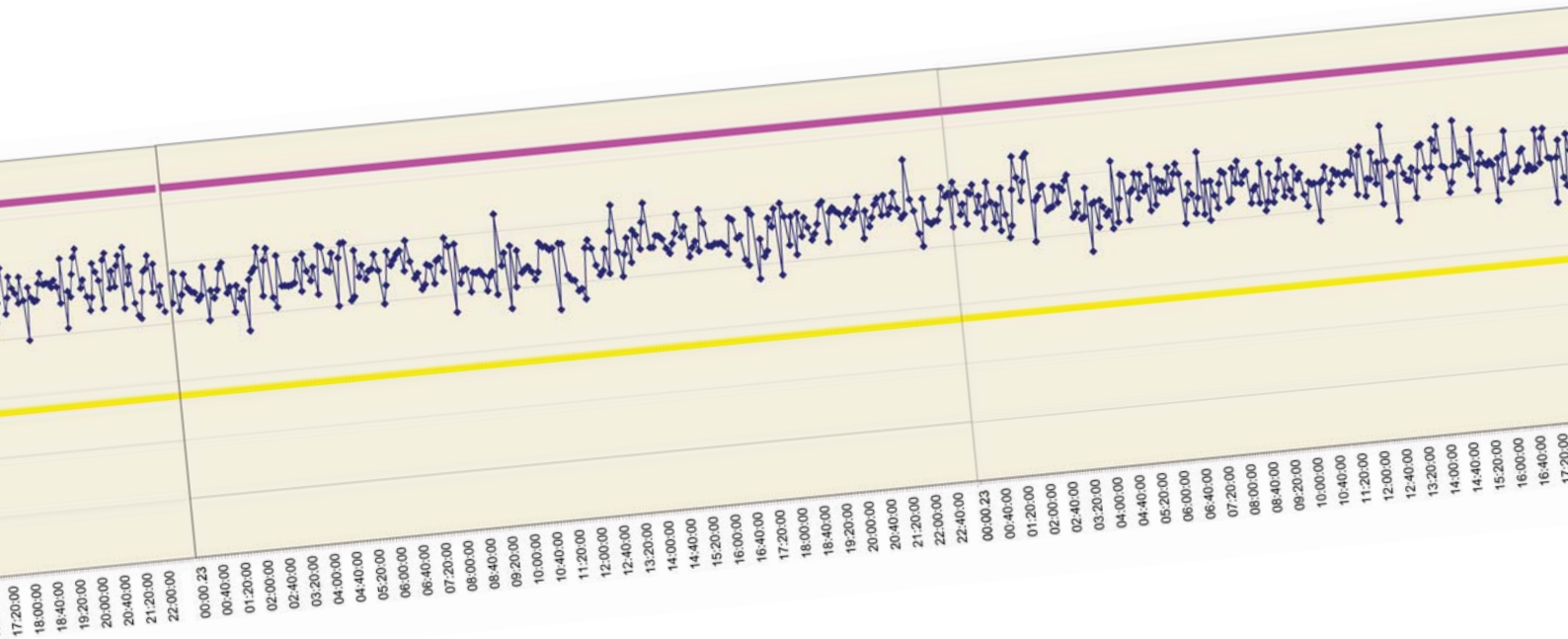

## Applications

High reliability, fast continuous response and excellent repeatability make the D86 Boiler ideal for increasing yields and improving blending operations and controlling distillation column to tight specifications in:

- Crude Distillation Units
- Blenders
- Towers
- Visbreakers
- Reformers

## Options

- Cetane Index
- Auto calibration and validation
- Stream switching (3 available)
- Up to 4 external alarm inputs
- Choice of communications available
- TCP/IP networking and modbus via RS485

# D86 Boiler

## Specification

<i>Type of Analyser</i>	Continuous Single Point Distillation
<i>Application</i>	Boiling Point Calculated Cetane Index (optional, requires density input)
<i>Analyser Standard Range</i>	Temperature 50 – 400°C for 5% – 95% distilled
<i>Repeatability</i>	Surpasses ASTM/ISO test methods
<i>Certification</i>	ATEX certified to EN60079-0, 60079-1, 60079-7 and 60079-1 I II 2G EEx d IIB + H <sub>2</sub> T4 GOST CE Mark
<i>Response Time</i>	Approximately 2 minutes for a step change in sample characteristic
<i>Local Display</i>	Colour LCD Display
<i>Communications</i>	Modbus RS485 RTU, RS232. 4-20mA, TCP/IP available
<i>Sample inlet temperature</i>	65°C maximum (must be at least 20°C below the initial boiling point temperature of the sample)
<i>Sample pressure</i>	1 barg minimum 7 barg maximum
<i>Ambient temperature</i>	5 – 40°C
<i>Power requirements</i>	100 to 120 or 200 to 240 Vac ± 10% 50/60Hz 1200VA maximum
Does not need an air conditioned shelter but protection from direct sun, wind and rain is recommended.	

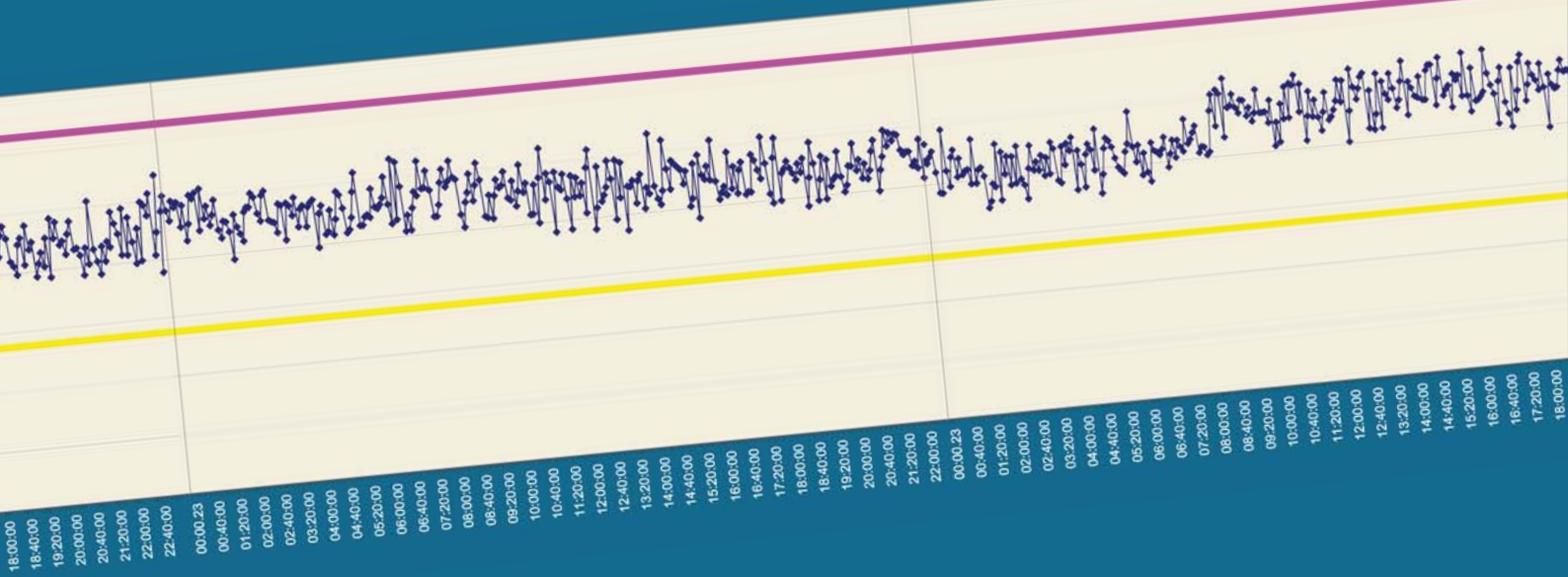

**ATAC Hallikainen** • Viscometers

- Pour Point • Vapour Pressure
- Opacity • Colour

**ATAC Hone** Boiling Point

- Multi-Point • Distillation
- Cloud Point • Freeze Point
- Flash Point • Sulphur in LPG

**ATAC Sysco** • Sample Systems • Shelters

- Turnkey Analytical Projects

**ATAC Sigma** • Calorimeters

- Moisture • Sulphur



THE MASTERS IN ANALYSIS

Analytical Technology & Control Limited

Broadway, Market Lavington, Devizes, Wiltshire SN10 5RQ England.

Tel: + 44 (0)1380 818411 Fax: + 44 (0)1380 812733

E-mail: [atac@atacuk.com](mailto:atac@atacuk.com) Website: [www.atacuk.com](http://www.atacuk.com)

ATAC'S policy is one of continuous development and, therefore, we reserve the right to change the specification of any product or component without prior notice.



**Hallikainen • Hone • Sysco • Sigma**