



MEASURES THE FLASH POINT OF PETROLEUM PRODUCTS

The Model 4400 Flashar is a completely automatic process stream analyser for the determination of flash point. The analysis can be performed to correlate with either the ASTM D93 or D56 standard test.

TYPICAL APPLICATIONS

- The monitoring of crude distillation sidestream strippers.
- Heating oil blending.

PRINCIPLE OF OPERATION

Flash points are determined by a particular vapour / air concentration above the surface of the liquid hydrocarbons. When a critical concentration is reached, flashing occurs on applying a test flame. The flash point of a liquid hydrocarbon is influenced largely by the lighter, more volatile components, since these are more easily vapourised.

In the Flashar Continuous Flash Point Analyser a test flame, as specified for the standard laboratory test, is not used to detect the flash point. Instead, a platinum / palladium catalyst is used to detect the critical hydrocarbon vapour concentration that corresponds with the flash point. This particular vapour / air mixture reacts on the catalyst surface to produce a reproducible catalyst temperature. It is the difference between this temperature and the temperature caused by concentrations other than the critical (flash point) concentration that is used to control the heat applied to the fresh sample feed before it is mixed with air. If the vapour / air mixture flowing over the catalytic detector is below flash point concentration, then the detector temperature falls. This is sensed, compared with the "set point" temperature for the flash point concentration, and the difference used to increase the heat to the liquid feed. As the sample temperature increases more vapourisation occurs, until the flash point concentration is reached and the detector is again at the "set point" temperature. The reverse occurs when the vapour / air mixture is above flash point concentration, and the heating of the liquid is reduced.

The "set point" temperature is adjusted to correlate the output of the analyser to the relevant standard laboratory test method. A catalytic detection method was chosen to determine flash point because the catalyst lowers the temperature at which oxidation of the hydrocarbon vapour occurs. By reacting at a lower temperature than either a test flame or sparking electrical contacts, the carbonisation of product is virtually eliminated and "coking" problems vastly reduced.

The oxidation temperature is reduced by the catalyst owing to absorption of the hydrocarbon molecules on the catalyst surface. Their chemical bonds are weakened and they become more reactive to oxygen, (catalytic oxidation).

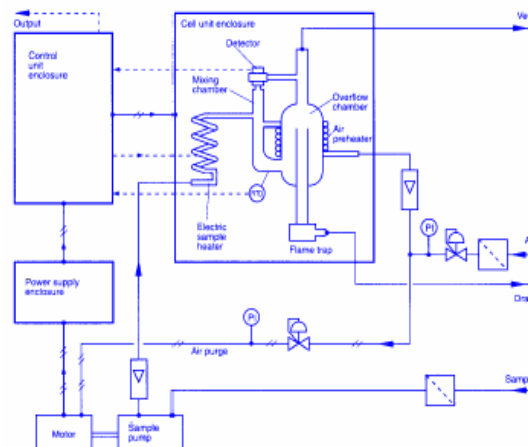

ONE OF THE ATAC RANGE OF PROCESS ANALYSERS

The mode of operation can be explained by referring to the schematic diagram. A flow of clean, fresh sample enters the main heater at a flow rate determined by the integral sample pump. It enters the mixing chamber where it is mixed with air preheated by the hot sample. Excess sample passes to the overflow chamber and then to drain via the flame trap. The vapour / air mixture produced passes through the heated detector housing where the vapour concentration is detected by means of the catalytic oxidation of the vapour. It is then vented.

The detector, which is in the vapour / air stream above the mixing chamber, produces a variable voltage output which is dependent upon the catalyst temperature, (and hence vapour concentration). This voltage is the input to the main amplifier and is compared with the "set point" temperature value. A voltage is produced at the output which is proportional to the input error.

The amplifier output is used to control the ON / OFF ratio of the electrical supply to the main heater and, thus, the temperature of the incoming sample. If the detector output is low with respect to the "set point", then the temperature of the incoming sample is raised and, with the detector output high, the reverse is true. When the detector output is identical with the "set point" value, then the heater will control the temperature of the incoming sample to produce a vapour concentration corresponding to the critical flash point concentration.

The flash point temperature is measured by a platinum resistance thermometer attached to the liquid section of the mixing chamber. An amplifier converts this signal to a standard 4-20 mA dc output for transmission purposes.

The Flashar performs exactly the same function as the standard ASTM / IP laboratory tests, but provides "on-line" sample checking automatically on a continuous basis, following changes in product flash point information as they occur and giving quick, precise flash point information.

The analyser is built with solid state circuitry and has no moving parts or sparking contacts. It is extremely reliable and is designed for easy on-line checking, with the facility for introduction of test samples. The Flashar is supplied complete with flow control systems for sample and air.

SPECIFICATION

Analysar performance

Range	25°C to +175°C. upper range limit is dependent upon sample composition
Span	50°C Min.
Repeatability	± 1°C.
Response time	3 minutes approximately
Dead time	1 minute approximately.

Output signal

Range	4 - 20 mA fully isolated
Load impedance	700 ohms maximum connected load.

Alarm and status contacts Volt free contacts rated 0.5 amps 250V ac are provided for:
high sample temperature
air purge / power failure.
Off line.

Sample conditions required at inlet

Pressure	0.4 to 0.7 bar g.
Temperature	≥ 10°C below expected flash point
Flow	2 litres / hour free of water and entrained solids.
H ₂ S content	2% maximum

Sample conditioning

Complete systems can be supplied to pre - condition process sample to the conditions required at the analyser inlet.

Sample disposal

The analyser sample outlet must be connected to a system which is at atmospheric pressure. Sample recovery systems are available.

Analysar vent

The analyser must be vented to atmosphere.

Utility requirements

Power supply

Voltage	115V or 230V ac ±10%
Frequency	50 or 60 Hz

Air supply

Pressure	3 to 7 bar g dry instrument air
Consumption	50 litres/hour.

Local display

LED displays provide status information. Output signal is displayed on an analogue meter.

Standard connections

Sample in	¼" API (female)
Drain and vent	½" API (female)
Air	¼" API (female)
Power and signals	PG16

Environmental protection

Whilst the analyser is weatherproof to IP55 and will operate in ambient temperatures within the range +5°C to +30°C, a weatherproof shelter is strongly recommended.

Dimensions and weight

Height	1750 mm
Width	650 mm
Depth	330 mm
Weight	160 kg approximately

Explosion protection

The analyser is ATEX certified
Ⓔ II 2G EEx d IIB T3 or T4 (T_{amb} +55)
for use in zone 1 hazardous areas.
Certificate no. DEMKO 03 ATEX 135888

Options

- Automatic calibration sample injection.

4402 APR 2007

For further information contact :-



e-mail: atac@atacuk.com
web: www.atacuk.com

Sales Office
ATAC House, The Green,
Warlingham, Surrey,
CR6 9NA, England.
Tel: +44 (0)1883 626583
Fax: +44 (0)1883 625430

Manufacturing Site
Broadway, Market Lavington,
Devizes, Wiltshire,
SN10 5RQ, England.
Tel: +44 (0)1380 818411
Fax: +44 (0)1380 812733